

# **SCHMEISER®**

## **TANDEM DISC**

### **OWNERS & PARTS**

### **MANUAL**



3pt. models: **TSN™**, **RTM™**, & **RTH™**  
Pull Type models: **PTM™** & **PTH™**

**T. G. SCHMEISER CO., INC.**

P.O. BOX 1047 FRESNO, CA 93714-1047

(559) 268-8128 FAX (559) 268-3279

[www.tgschmeiser.com](http://www.tgschmeiser.com)

VERSION 1.0  
OCTOBER 2005

## INTRODUCTION

Your Schmeiser Tandem Disc™ is designed to give you many years of dependable service. This manual has been prepared to instruct you in the safe and efficient operation of this machine. Read and study it thoroughly. Follow all instructions carefully.

Should your Tandem Disc require replacement parts, go to your Schmeiser® dealer. Always order genuine Schmeiser replacement parts.

It is important that you complete and send in your Warranty Card because it is not valid unless it is on file at Schmeiser. If you need information not contained in this manual, contact your Schmeiser dealer.

This manual covers the following Schmeiser Tandem Disc models: TSN™, RTM™, RTH™, PTM™, and PTH™. Use the table of contents as a guide to locate the proper information for your selected model.

Space has been provided below for you to record the model number and serial number of your Schmeiser Tandem Disc. Be sure to bring this information with you to your dealer when ordering parts or attachments for your Tandem Disc.

Thank you for buying a Schmeiser Tandem Disc™.

SERIAL NUMBER \_\_\_\_\_

MODEL NUMBER \_\_\_\_\_

DATE PURCHASED \_\_\_\_\_

DEALER NAME \_\_\_\_\_

SCHMEISER® reserves the right to make improvements in design or changes in specification at any time without incurring any obligation to owners of equipment previously sold.

Copyright © 2005. T. G. Schmeiser Co., Inc. All rights reserved. This manual, or parts thereof, may not be reproduced in any form without permission.

# SCHMEISER®

## TANDEM DISC MODELS



**TSN – TANDEM SUPER NARROW™**



**RTM – REVERSIBLE TANDEM MEDIUM™**



**RTH – REVERSIBLE TANDEM HEAVY™**



**PTM – PULL TYPE TANDEM MEDIUM  
WHEEL DISC™**



**PTH – PULL TYPE TANDEM HEAVY  
WHEEL DISC™**

**SCHMEISER® TANDEM DISC  
TABLE OF CONTENTS**

Introduction ..... 2

Disc Models (covered in this manual)..... 3

Table of Contents..... 4

Safety Sheet..... 5

TSN Main Frame Parts..... 6

RTM Main Frame Parts ..... 7

RTH Main Frame Parts..... 8

PTM & PTH Main Frame Parts ..... 9

PTM & PTH Leveling Spring Assmy..... 10

2 Blade Gang Assembly .....11

3 Blade Gang Assembly .....12

4 Blade Gang Assembly .....13

5 Blade Gang Assembly.....14

Disc Scraper Assembly..... 15

Trunnion Bearing Assembly..... 16

Blade Extension Diagram.....17

Inside Blade Extension Assembly.....18

Outside Blade Extension Assembly .....19

Limited Warranty..... 20

# SAFETY

The safe operation of any machinery is an important concern to farmers and manufactures. There are obvious and hidden potential hazards involved in the operation of this implement. Carefully read and follow all safety precautions before operation. Serious injury or death may occur unless care is taken to insure the safety of both the operator and any other persons in the area.

1. Never permit anyone to ride on or walk beside the implement when moving.
2. Never permit anyone to ride on tractor when implement is being moved.
3. Before starting machine, always check area around machine to verify that all personnel are clear.
4. Never connect hydraulic lines or operate any portion of the machine unless machine is hitched to tractor.
5. Do not operate hydraulic systems when hydraulic leaks are present.
6. Before transport or unhitching, always tie back hydraulic hoses.
7. Do not exceed 2000 psi working pressure or 2500 psi maximum pressure on hydraulic system.
8. When performing operating functions, never allow anyone to be near the implement or the tractor.
9. Do not enter tractor when tractor is moving. Avoid serious injury or death from contact with rotating tires. Enter and exit the tractor only when it is completely stopped.
10. Always operate machine in a careful, controlled manner.
11. Personnel operating and working with this machinery must not wear loose, dangling or unbuttoned clothing which could tangle in machinery.
12. Be sure of water, gas, sewer, or electric line locations before operating implement.
13. When in transport, use accessory lights and devices for adequate warning to operators of other vehicles.
14. Comply with all Federal, State and local laws when traveling on public roads.
15. Use "Slow Moving Vehicle" emblem for warning vehicles approaching from the rear.
16. When transporting, remember that the implement may be wider than your tractor and extreme care must be taken to allow for safe clearance.
17. Never allow inexperienced or untrained personnel to operate the implement or tractor.
18. When using compressed air to clean implement, wear safety glasses.
19. Check all fasteners for tightness or damage before and after operation. Repair immediately if required.
20. Before transport, inspect lug bolts and tire inflation.
21. Store implement in a stable position. Insure that safety stands are extended and locked in place before detaching from tractor. Before unhitching, place chocks in front and behind all transport wheels to prevent rolling when unhitched and parked.
22. Always use two people to handle heavy, unwieldy components during assembly, installation, removal, or moving.



SERIAL NUMBER: \_\_\_\_\_

MODEL NUMBER: \_\_\_\_\_

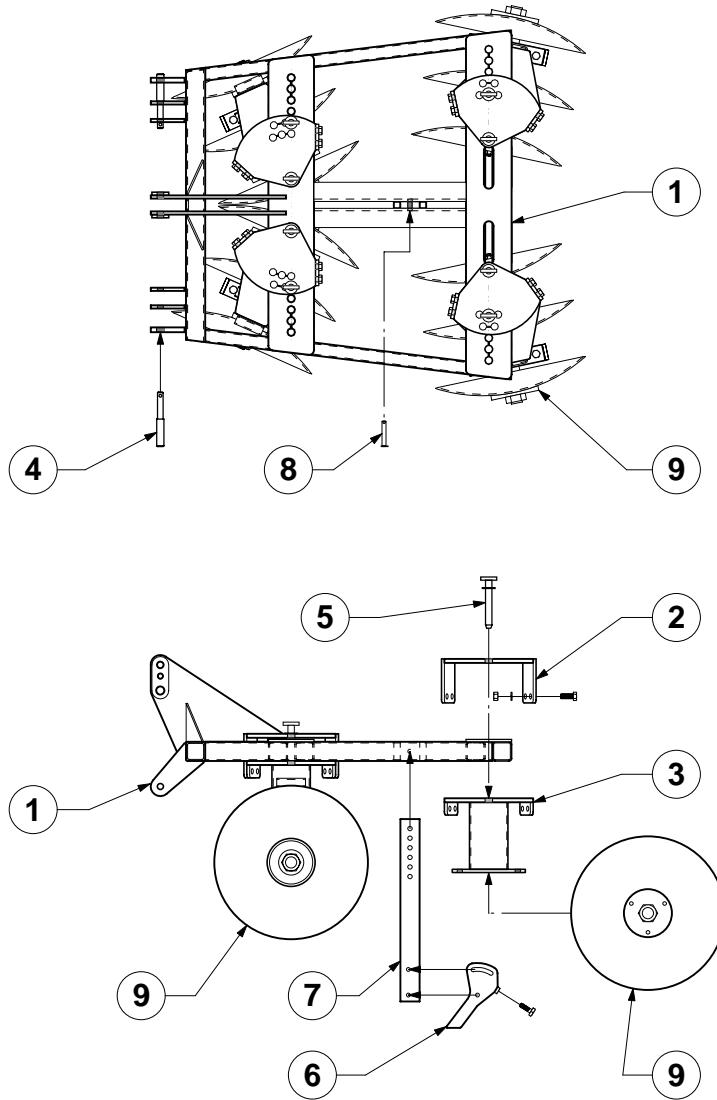

<u>Ref No.</u>	<u>Old Part No.</u>	<u>New Part No.</u>	<u>Description</u>	<u>Qty.</u>
1.	-----	TSN-45A000 TSN-55A000	Main Frame for 45" Units Main Frame for 55" Units	1 1
2.	TSN-B	TSN-00B000L(R)	Gang Top Plate Left and Right	2
3.	TSN-T	TSN-(00)T000L(R)	Gang Frame (Specify Gang Location & Blade Q-ty)	1
4.	RTM-A-18	GPN-18CA12	Category I & II Clevis Pull Pin	2
5.	RT-C-03	RTU-00C100	1" Dia. Gang Frame Adjustment Pin	8
6.	SD-H-01	GDP-00H100	Foot Attachment	1
7.	SD-H-02	GDP-00H200	1" x 3" Standard	1
8.	SD-H-03	GDP-00H300	5/8" Dia. Middle Buster Pin	1
9.	-----	-----	Gang Assembly	4



SERIAL NUMBER: \_\_\_\_\_  
 MODEL NUMBER: \_\_\_\_\_

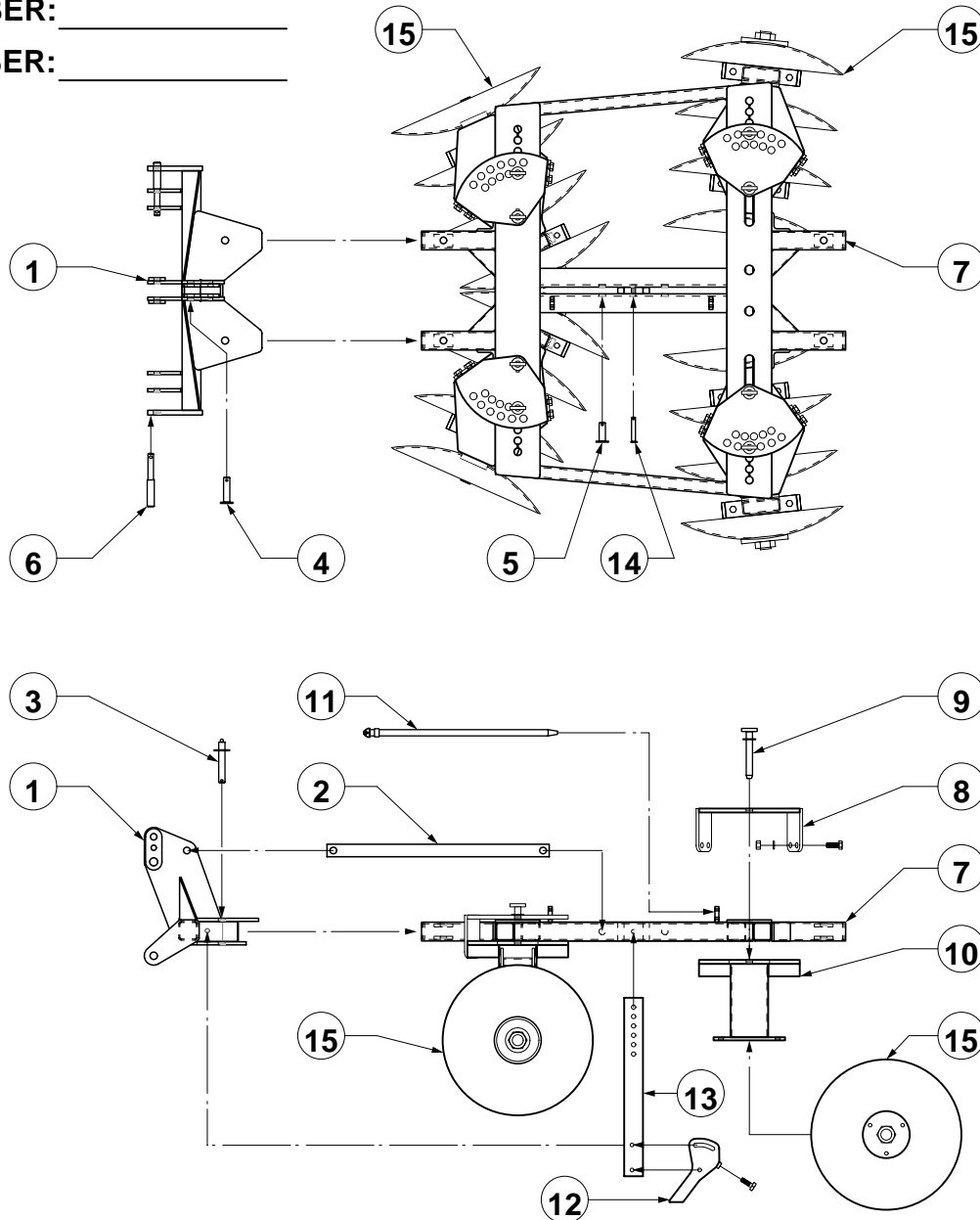

<u>Ref No.</u>	<u>Old Part No.</u>	<u>New Part No.</u>	<u>Description</u>	<u>Qty.</u>
1.	RTM-A	RTM-00A000	Reversible Three Point Hitch	1
2.	RTM-A-14	RTM-00A014	3/4" x 2" Hitch Center Brace	1
3.	RTM-A-15	GPN-16080L	1" Dia. x 5" Hitch Lock Pin	2
4.	RT-A-16	RTU-00A016	1" Dia. x 4" Brace Clevis Pin	1
5.	RT-A-17	GPN-16X048	1" Dia. x 3" General Clevis Pin	1
6.	RTM-A-18	GPN-18CA12	Category I & II Clevis Pull Pin	2
7.	-----	-----	Main Frame	1
8.	RT-C	RTU-00C000	Reversible Gang Top Plate	4
9.	RT-C-03	GDP-00GPIN	1" Dia. Gang Frame Adjustment Pin	8
10.	RT-D	RTU-(00)D000L(R)	Reversible Gang Frame (Specify Gang Location & Blade Qty.)	4
11.	SD-G	GDP-00G000	Gang Adjustment Rod (for 14 to 20 Blade Units Only)	1
12.	SD-H-01	GDP-00H100	Foot Attachment	1
13.	SD-H-02	GDP-00H200	1" x 3" Standard	1
14.	SD-H-03	GDP-00H300	5/8" Dia. Middle Buster Pin	1
15.	-----	-----	Gang Assembly	4



SERIAL NUMBER: \_\_\_\_\_

MODEL NUMBER: \_\_\_\_\_

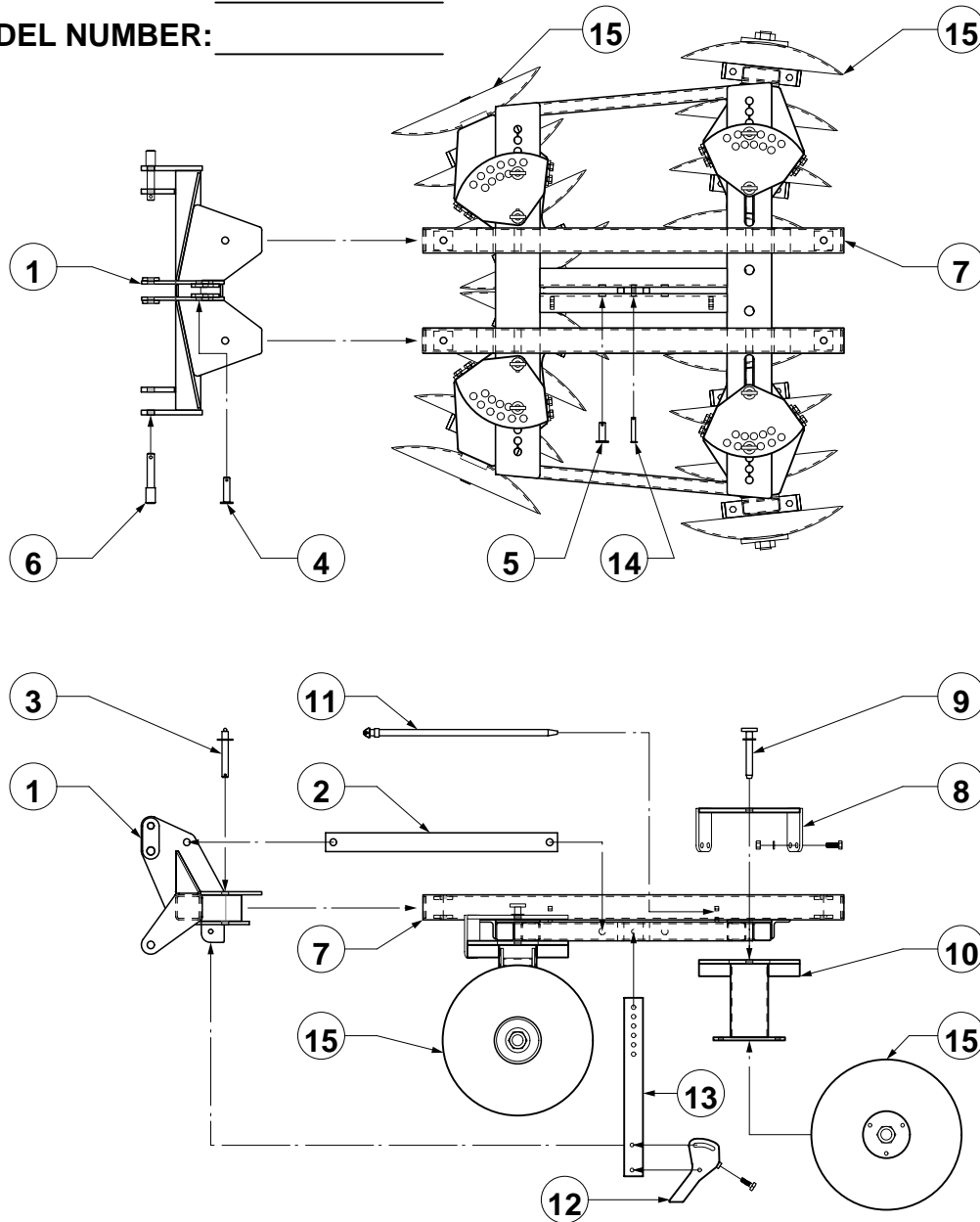

<u>Ref No.</u>	<u>Old Part No.</u>	<u>New Part No.</u>	<u>Description</u>	<u>Qty.</u>
1.	RTH-A	RTH-00A000	Reversable Three Point Hitch	1
2.	RTH-A-14	RTH-00A014	1" x 3" Hitch Center Brace	1
3.	RTH-A-15	GPN-16096L	1" Dia. x 6" Hitch Lock Pin	2
4.	RT-A-16	RTU-00A016	1" Dia. x 4" Brace Clevis Pin	1
5.	RT-A-17	GPN-16X048	1" Dia. x 3" General Clevis Pin	1
6.	RTH-A-18	GPN-24CA02	Category II Clevis Pull Pin	2
7.	-----	-----	Main Frame	1
8.	RT-C	RTU-00C000	Reversable Gang Top Plate	4
9.	RT-C-03	GDP-00GPIN	1" Dia. Gang Frame Adjustment Pin	8
10.	RT-D	RTU-(00)D000L(R)	Reversable Gang Frame (Specify Gang Location & Blade Qty.)	4
11.	SD-G	GDP-00G000	Gang Adjustment Rod (for 14 to 20 Blade Units Only)	1
12.	SD-H-01	GDP-00H100	Foot Attachment	1
13.	SD-H-02	GDP-00H200	1" x 3" Standard	1
14.	SD-H-03	GDP-00H300	5/8" Dia. Middle Buster Pin	1
15.	-----	-----	Gang Assembly (See Assembly Drawing)	4





SERIAL NUMBER: \_\_\_\_\_

MODEL NUMBER: \_\_\_\_\_

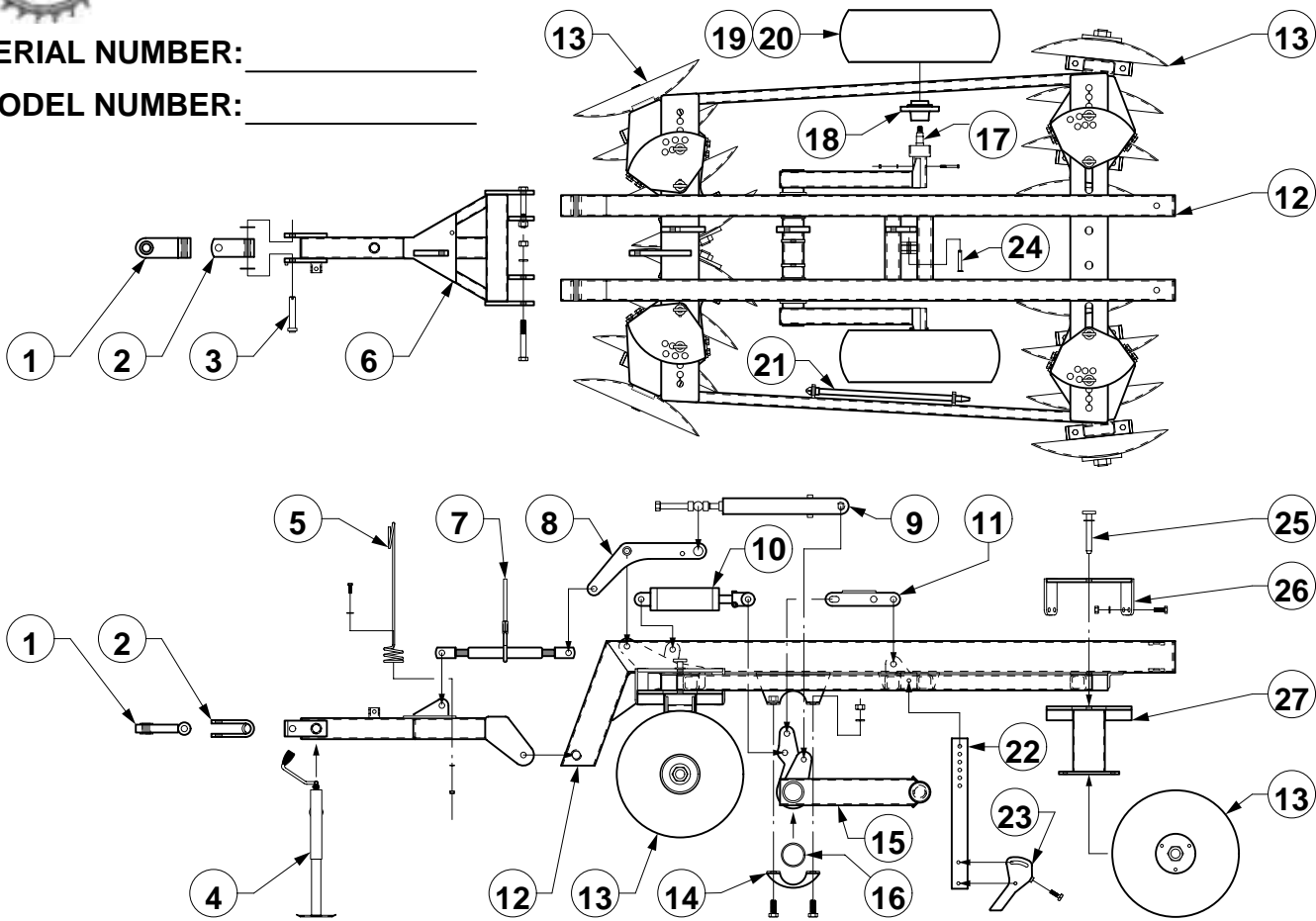

Ref No.	Old Part No.	New Part No.	Description	Qty.
1.	TB4-J2	GWD-150SC1	General Clevis Hitch (for PTH units)	1
2.	TPP 3021	GWD-200DC2	3-1/2" Tongue Clevis (for PTM units)	1
3.	PT-A-11	GPN-18A300	1-1/8" X 6" Clevis Pin	1
4.	-----	GJK-2KTW10	2000 lbs. Capacity Top Winding Jack Stand	1
5.	-----	GHD-HHOLD1	Hydraulic Hose Line Support	1
6.	PT-A	PTU-00A000	Pull Frame	1
7.	PT-Q9	GJK-RATCHJ	20" Ratchet	1
8.	PTH-Q1-01	PTH-00Q100	Pivot Link (for PTH units)	2
	PTM-Q1-01	PTM-00Q100	Pivot Link (for PTM units)	2
9.	PT-Q(2-7)	-----	Leveling Adjustment Spring Assembly (See Assembly Drw)	1
10.	3X8SC	GHC-3008SC	3" X 8" Stroke Control Cylinder	1
11.	PT-Q8	PTU-00Q800	Lockout Bar	1
12.	-----	-----	Main Frame	1
13.	-----	-----	Gang Assembly (See Gang Assembly Drawing)	4
14.	PT-B-22	PTU-00B200	Tire Axle Bearing Housing Cap	2
15.	PT-P	PTU-(00)P000	Tire Axle Frame (Specify Size)	1
16.	PT-P-12	PTU-00P012	Tire Axle UHMW Bearing	2
17.	PT-P-11	PTU-00P011	2" Replaceable Wheel Spindle	2
18.	SLL 1415	GHB-6X6HUB	6 on 6 Hub Assembly (Complete)	2
19.	SLL 1450	GWT-156LBH	15" 6 on 6 Wheel	2
20.	-----	GWT-951508	9.5 x 15 8 Ply Tires (for PTH units)	2
	-----	GWT-761508	7.6 x 15 8 Ply Tires (for PTM units)	2
21.	SD-G	GDP-00G000	Gang Adjustment Rod (for 14 to 20 Blade Units Only)	1
22.	SD-H-02	GDP-00H200	1" X 3" Standard	1
23.	SD-H-01	GDP-00H100	Foot Attachment	1
24.	SD-H-03	GDP-00H300	5/8" Dia. Middle Buster Pin	1
25.	RT-C-03	GDP-00GPIN	1" Dia. Gang Frame Adjustment Pin	8
26.	PT-C	PTU-00C000L(R)	Gang Top Plate (2 L.H. / 2 R.H.)	4
27.	PT-D	PTU-(00)D000L(R)	Gang Frame (Specify Gang Location & Blade Quantity)	4

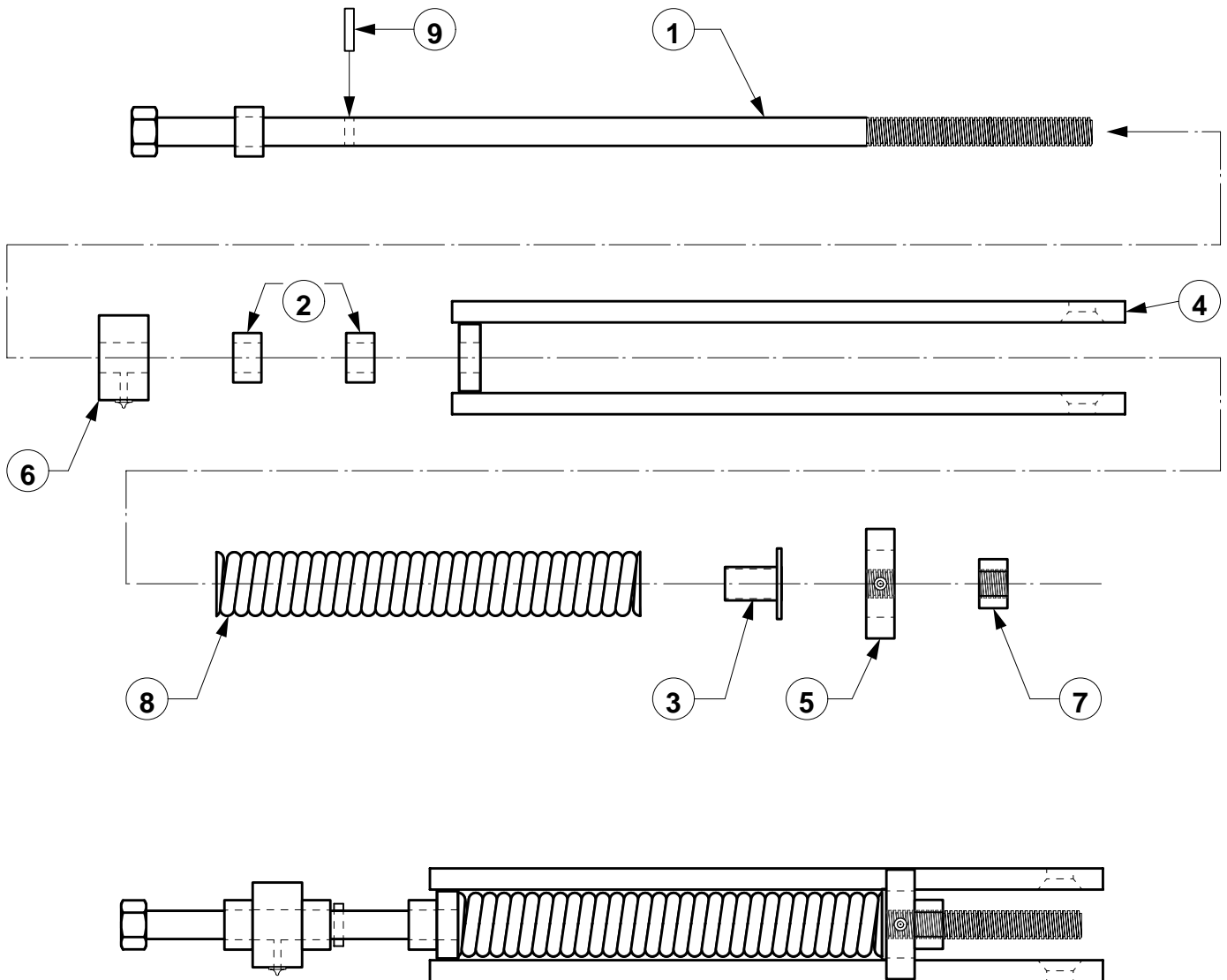

<u>Ref No.</u>	<u>Old Part No.</u>	<u>New Part No.</u>	<u>Description</u>	<u>Qty.</u>
1.	PT-Q2	PTU-00Q200	Leveling Adjustment Bolt	1
2.	PT-Q2-02	PTU-00Q202	Trunnion Bushing	2
3.	PT-Q3	PTU-00Q300	Spring Retainer Bushing	1
4.	PT-Q4	PTU-00Q400	Spring Clevis	1
5.	PT-Q5	PTU-00Q500	Spring Retainer Plate	1
6.	PT-Q6	PTU-00Q600	Adjustment Bolt Trunnion	1
7.	PT-Q7	PTU-00Q700	Adjustment Bolt Jam Nut	1
8.	PT-Q9	GSR-CM0201	2-1/4" Compression Spring	1
9.	PT-Q10	GPN-05X24R	5/16" x 1-1/2" H.D. Roll Pin	1

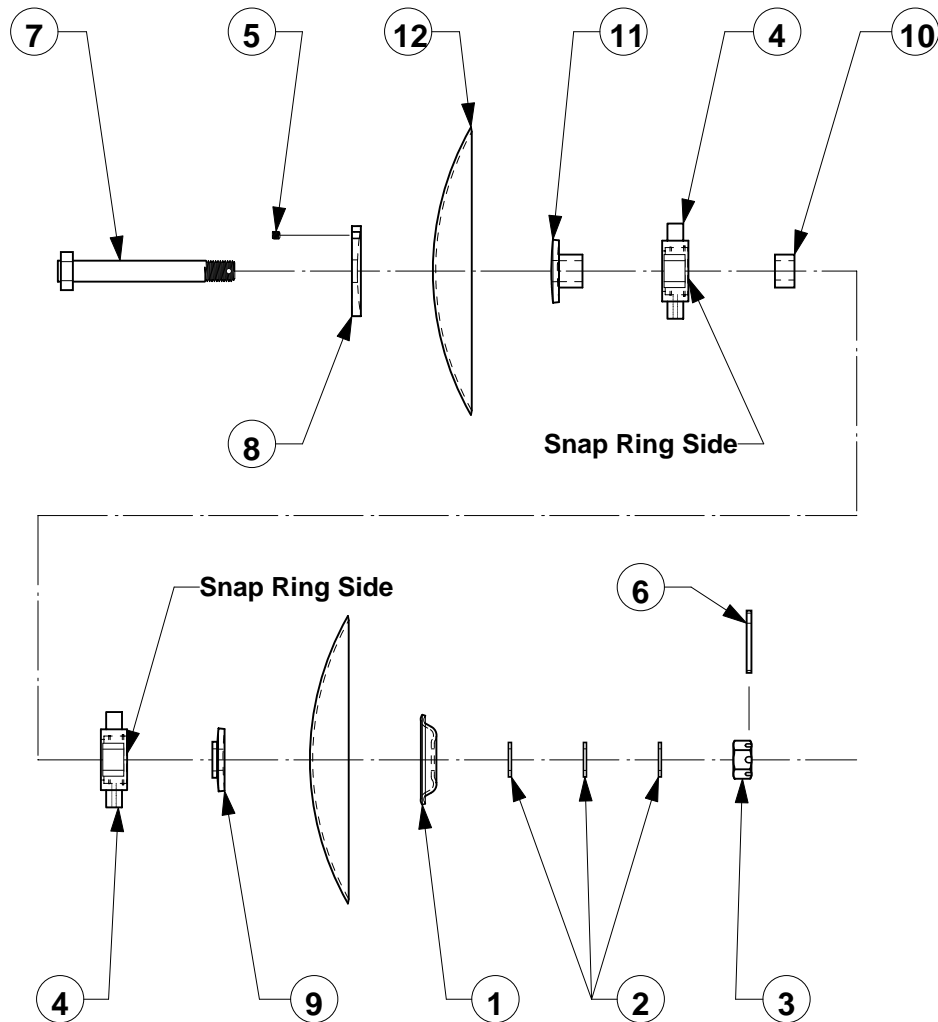

<u>Ref No.</u>	<u>Old Part No.</u>	<u>New Part No.</u>	<u>Description</u>	<u>Qty. / Gang</u>
1.	SD-175A-01	GDP-28SC01	1-3/4" Spring End Collar	1
2.	SD-175A-02	GDP-28FW01	1-3/4" Heavy Flat Washer	3
3.	SD-175A-03	HXNUTS28NC	1-3/4" N.C.Thread Slotted Nut	1
4.	SD-175-TB	GDP-28TRB2	1-3/4" Trunnion Bearing	2
5.	SD-175A-05	SSNC-10X10	5/8" x 5/8" Set Screw	3
6.	SD-175A-06	GPN-06X48C	3/8" x 3" Usable Cotter Pin	1
7.	SD-175B-2B	GDP-2BB000	1-3/4" 2 Blade Gang Axle	1
8.	SD-175B-03	GDP-00B003	1-3/4" Gang Axle End Plate	1
9.	TSN-D2B-01	TSN-00D100	Concave Bearing Spacer Wldm	1
10.	TSN-D2B-02	TSN-00D102	Middle Bearing Spacer	1
11.	TSN-D2B-03	TSN-00D200	Convex Bearing Spacer Wldm	1
12.	-----	-----	Disc Blade	2

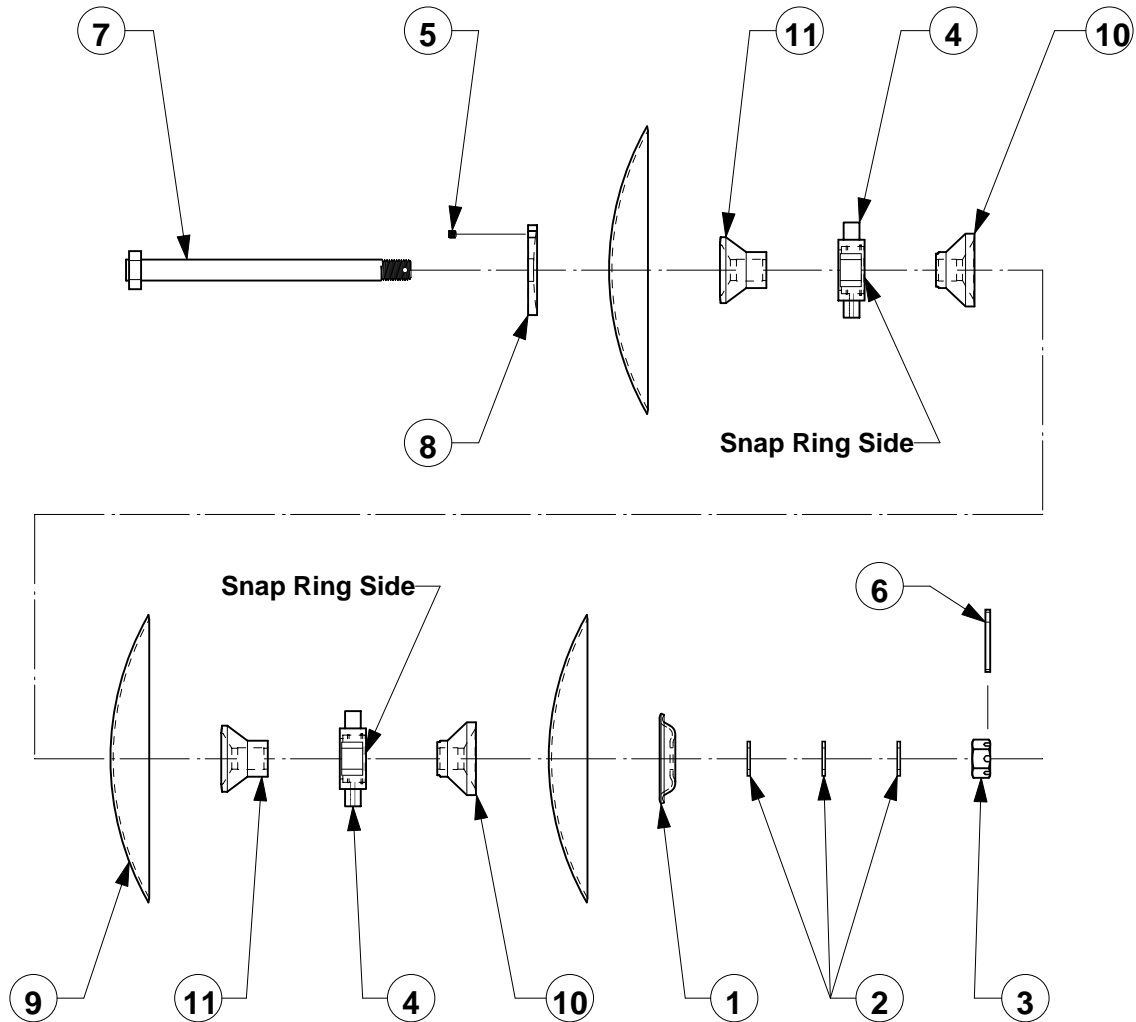

<u>Ref No.</u>	<u>Old Part No.</u>	<u>New Part No.</u>	<u>Description</u>	<u>Qty. / Gang</u>
1.	SD-175A-01	GDP-28SC01	1-3/4" Spring End Collar	1
2.	SD-175A-02	GDP-28FW01	1-3/4" Heavy Flat Washer	3
3.	SD-175A-03	HXNUTS28NC	1-3/4" N.C.Thread Slotted Nut	1
4.	SD-175-TB	GDP-28TRB2	1-3/4" Trunnion Bearing	2
5.	SD-175A-05	SSNC-10X10	5/8" x 5/8" Set Screw	3
6.	SD-175A-06	GPN-06X48C	3/8" x 3" Usable Cotter Pin	1
7.	SD-175B-3B	GDP-3BB000	1-3/4" 3 Blade Gang Axle	1
8.	SD-175B-03	GDP-00B003	1-3/4" Gang Axle End Plate	1
9.	-----	-----	Disc Blade	3
10.	SD-175D-01	GDP-28SHS2	1-3/4" Short Half Spool	2
11.	SD-175D-02	GDP-28LHS2	1-3/4" Long Half Spool	2

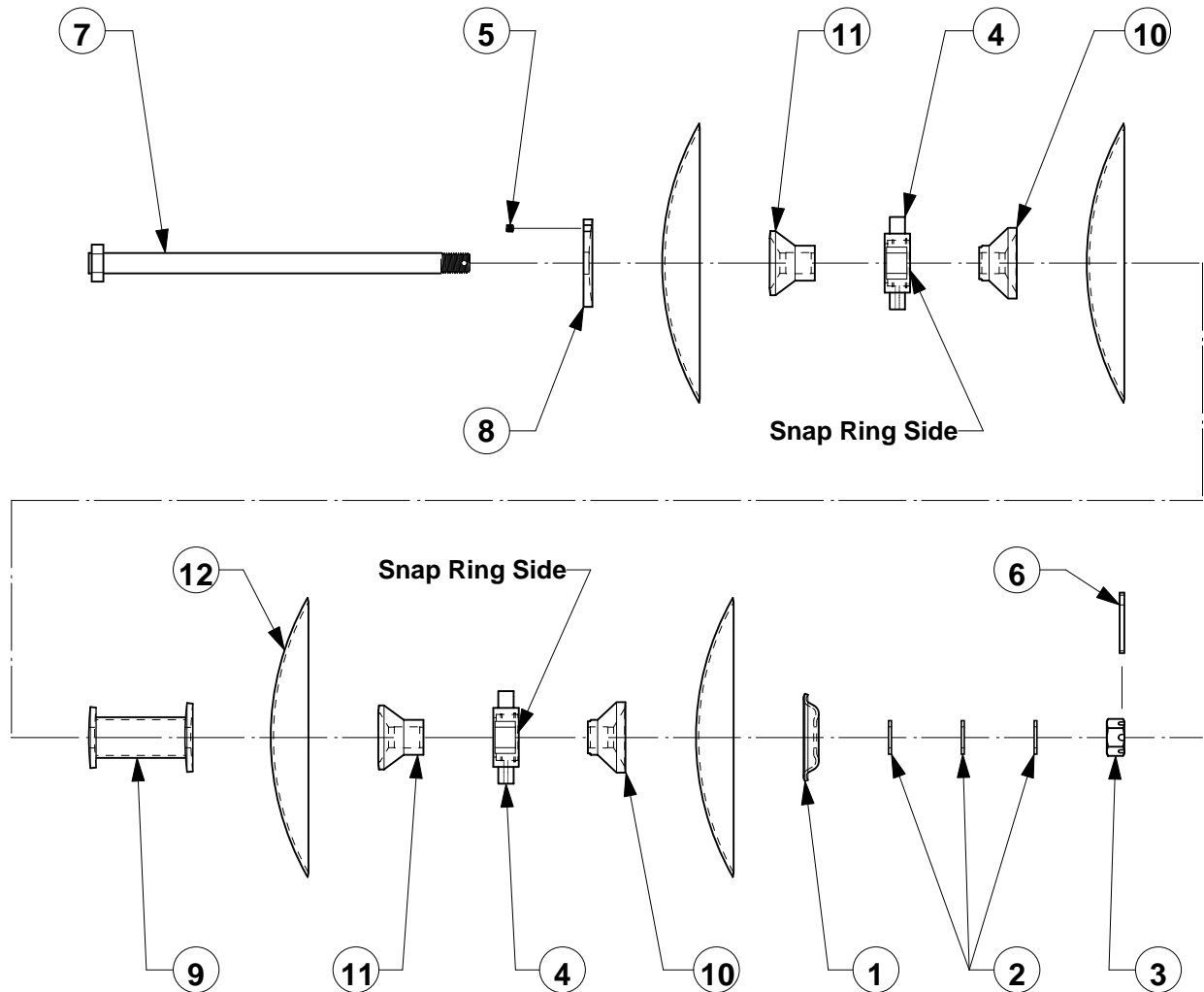

<u>Ref No.</u>	<u>Part No.</u>	<u>New Part No.</u>	<u>Description</u>	<u>Qty. / Gang</u>
1.	SD-175A-01	GDP-28SC01	1-3/4" Spring End Collar	1
2.	SD-175A-02	GDP-28FW01	1-3/4" Heavy Flat Washer	3
3.	SD-175A-03	HXNUTS28NC	1-3/4" N.C.Thread Slotted Nut	1
4.	SD-175-TB	GDP-28TRB2	1-3/4" Trunnion Bearing	2
5.	SD-175A-05	SSNC-10X10	5/8" x 5/8" Set Screw	3
6.	SD-175A-06	GPN-06X48C	3/8" x 3" Usable Cotter Pin	1
7.	SD-175B-4B	GDP-4BB000	1-3/4" 4 Blade Gang Axle	1
8.	SD-175B-03	GDP-00B003	1-3/4" Gang Axle End Plate	1
9.	SD-175C	GDP-28FS00	1-3/4" Full Spool Wldm	1
10.	SD-175D-01	GDP-28SHS2	1-3/4" Short Half Spool	2
11.	SD-175D-02	GDP-28LHS2	1-3/4" Long Half Spool	2
12.	-----	-----	Disc Blade	4

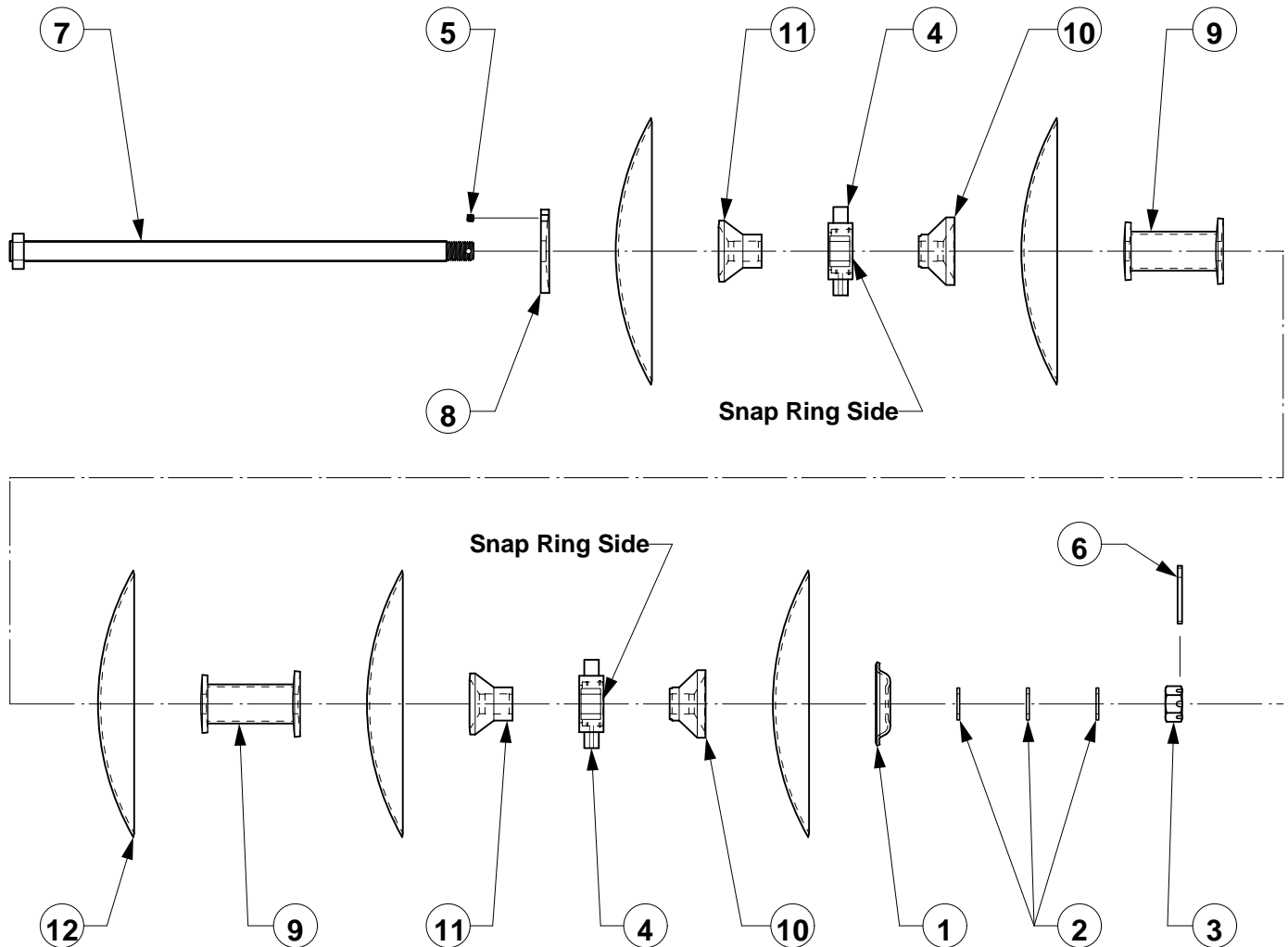

<u>Ref No.</u>	<u>Old Part No.</u>	<u>New Part No.</u>	<u>Description</u>	<u>Qty. / Gang</u>
1.	SD-175A-01	GDP-28SC01	1-3/4" Spring End Collar	1
2.	SD-175A-02	GDP-28FW01	1-3/4" Heavy Flat Washer	3
3.	SD-175A-03	HXNUTS28NC	1-3/4" N.C.Thread Slotted Nut	1
4.	SD-175-TB	GDP-28TRB2	1-3/4" Trunnion Bearing	2
5.	SD-175A-05	SSNC-10X10	5/8" x 5/8" Set Screw	3
6.	SD-175A-06	GPN-06X48C	3/8" x 3" Usable Cotter Pin	1
7.	SD-175B-5B	GDP-5BB000	1-3/4" 5 Blade Gang Axle	1
8.	SD-175B-03	GDP-00B003	1-3/4" Gang Axle End Plate	1
9.	SD-175C	GDP-28FS00	1-3/4" Full Spool	2
10.	SD-175D-01	GDP-28SHS2	1-3/4" Short Half Spool	2
11.	SD-175D-02	GDP-28LHS2	1-3/4" Long Half Spool	2
12.	-----	-----	Disc Blade	5

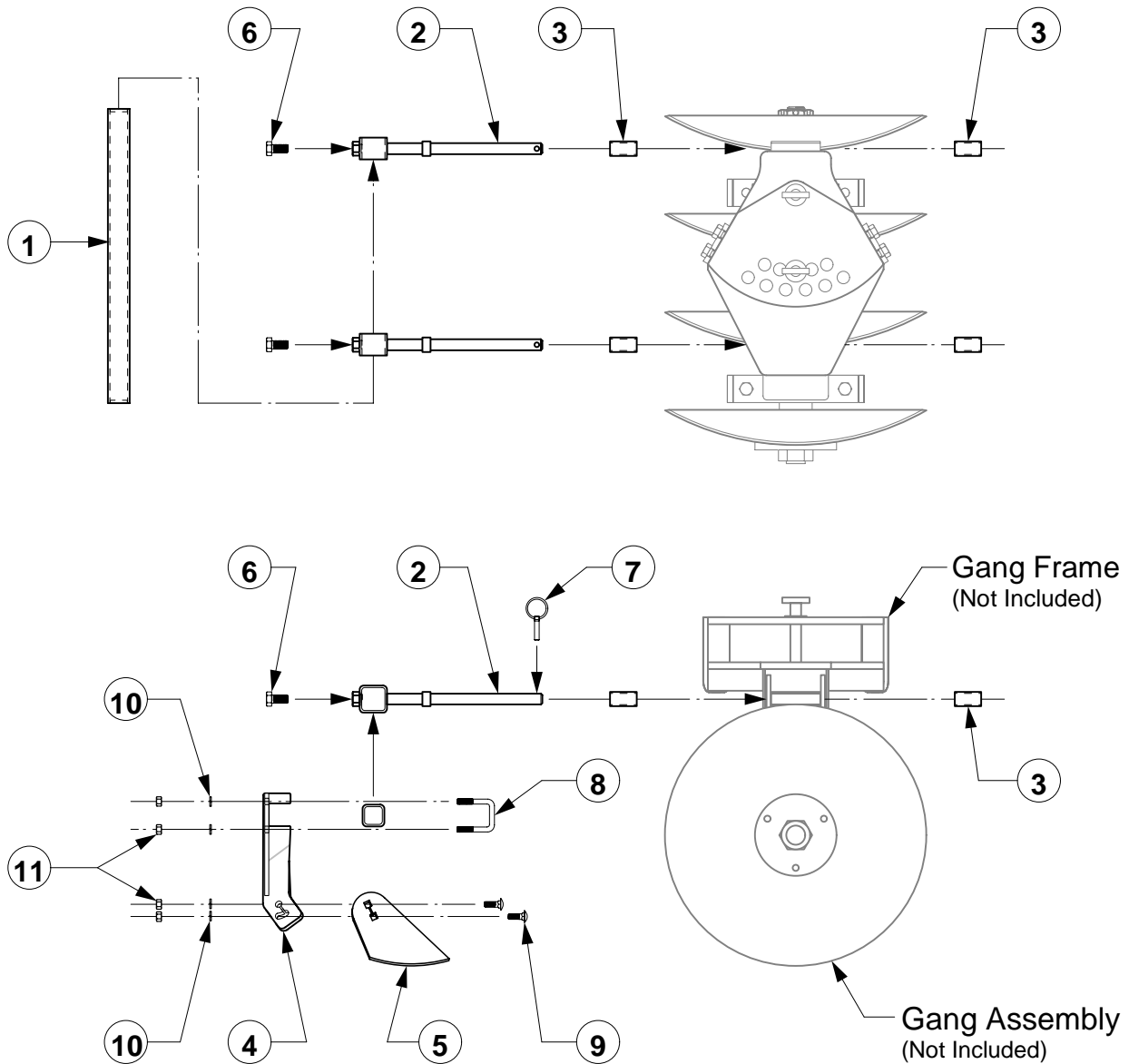

<u>Ref No.</u>	<u>Old Part No.</u>	<u>New Part No.</u>	<u>Description</u>	<u>Qty. / Kit</u>
1.	SDO-J1	GDP-00J100	Scraper Frame Cross Bar (specify blade qty.)	4
2.	SDO-J2	GDP-00J200	Scraper Frame Mounting Arm	8
3.	SDO-J3	GDP-00J300	Mounting Arm Spacer	16
4.	SDO-K1	GDP-00K100L	Disc Scraper Arm LH	Varies
		GDP-00K100R	Disc Scraper Arm RH	Varies
5.	SDO-K2	GDP-00K200	Disc Scraper	Varies
6.	FHB075X0150	CSNC512024	3/4" x 1-1/2" Gr. 5 Hex Bolt	8
7.	FLP044X0175	GPN-070LYN	7/16" x 1-3/4" Lynch Pin	8
8.	FUB050X0300	UBNC08X33S	1/2" x 3" Square Bend U-Bolt	1 per Scraper
9.	FCB050X0150	CBNC508024	1/2" x 1-1/2" Gr. 5 Carriage Bolt	2 per Scraper
10.	FLW050	LWASHER-08	1/2" Lock Washer	4 per Scraper
11.	FHN050	HXNUT-08NC	1/2" Hex Nut	4 per Scraper

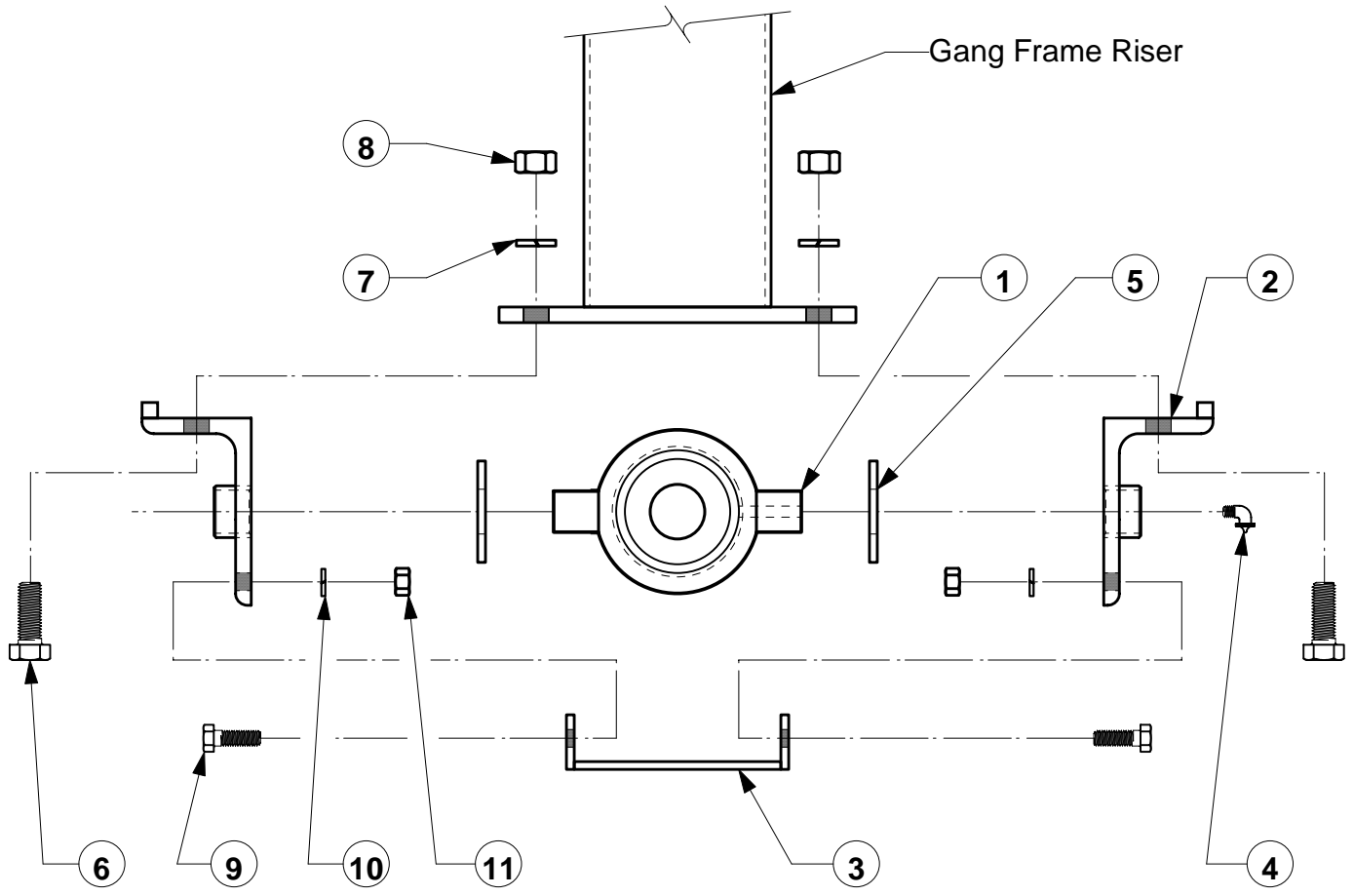

<u>Ref No.</u>	<u>Old Part No.</u>	<u>New Part No.</u>	<u>Description</u>	<u>Qty. / Gang</u>
1.	SD-175-TB	GDP-28TRB0	1-3/4" Trunnion Bearing Ass'y	2
2.	SD-175E	GDP-00E000	Trunnion Bearing Bracket	4
3.	SD-175F	GDP-00F000	Trunnion Bearing Wear Guard	2
4.	SD-175A-04	GMB-ZERK90	1/8" N.P.T. 90 Grease Zerk	2
5.	-----	FWASHER-22	1-3/8" Flat Washer z.p.	4
6.	-----	CSNC512032	3/4" x 2" Gr. 5 Hex Bolt z.p.	4
7.	-----	LWASHER-12	3/4" Lock Washer z.p.	4
8.	-----	HXNUT-12NC	3/4" Hex Nut z.p.	4
9.	-----	CSNC508024	1/2" x 1-1/2" Gr. 5 Hex Bolt z.p.	4
10.	-----	LWASHER-08	1/2" Lock Washer z.p.	4
11.	-----	HXNUT-08NC	1/2" Hex Nut z.p.	4



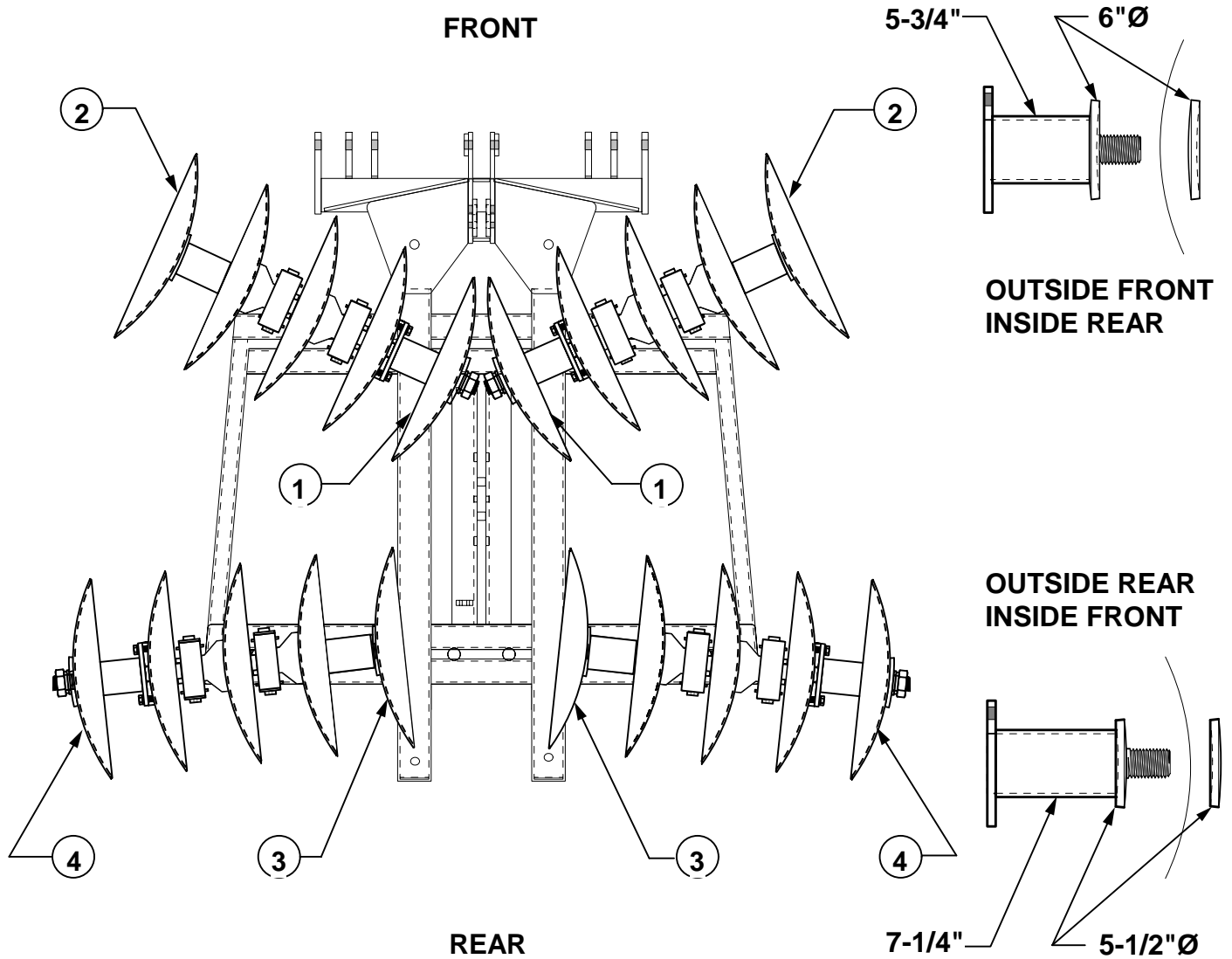

<u>Ref No.</u>	<u>Part No.</u>	<u>Description</u>	<u>Qty.</u>
1.	DBEIF	Disc Blade Extension Inside Front - Long	2
2.	DBEOF	Disc Blade Extension Outside Front - Short	2
3.	DBEIR	Disc Blade Extension Inside Rear - Short	2
4.	DBEOR	Disc Blade Extension Outside Rear - Long	2

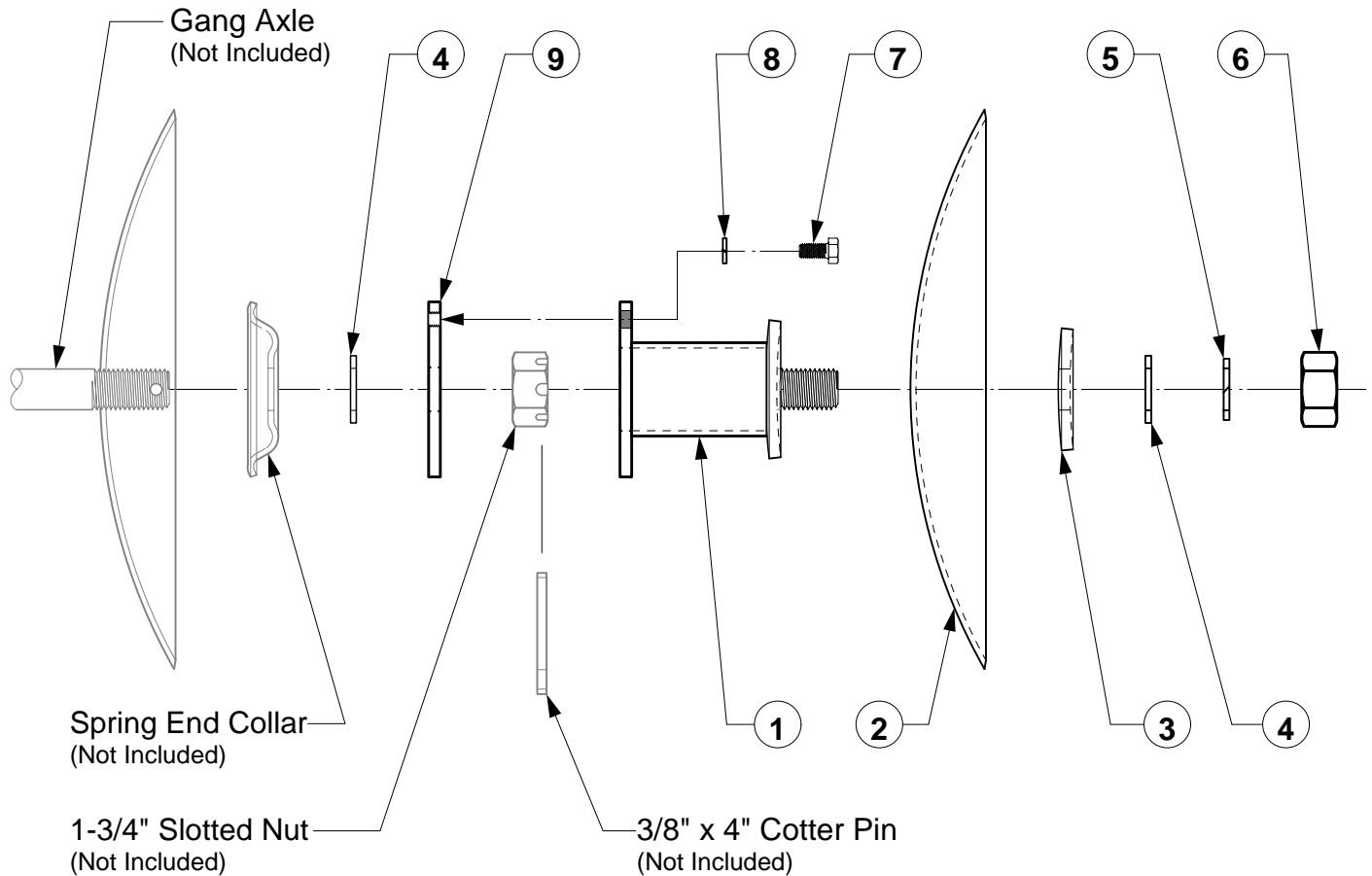

Note: Items "Not Included" are mounted on end of each disc gang axle.

<u>Ref No.</u>	<u>Old Part No.</u>	<u>New Part No.</u>	<u>Description</u>	<u>Qty. / Set</u>
1.	SD-175ib	GDP-IBE000	Inside Blade Extension	2
2.	-----	-----	Disc Blade	2
3.	SD-175C-02	GDP-28FS02	5-1/2" Dia. End Plate	2
4.	FFW175	FWASHER-28	1-3/4" Flat Washer	2
5.	FLW175	LWASHER-28	1-3/4" Lock Washer	2
6.	FJN175	HXNUTJ28NC	1-3/4" Jam Nut	2
7.	FHB063X0125	CSNC510020	5/8" X 1-1/4" Gr. 5 Hex Bolt	6
8.	FLW063	LWASHER-10	5/8" Lock Washer	6
9.	SDO-175i-02	GDP-00I002	Blade Extension Mounting Plate	2

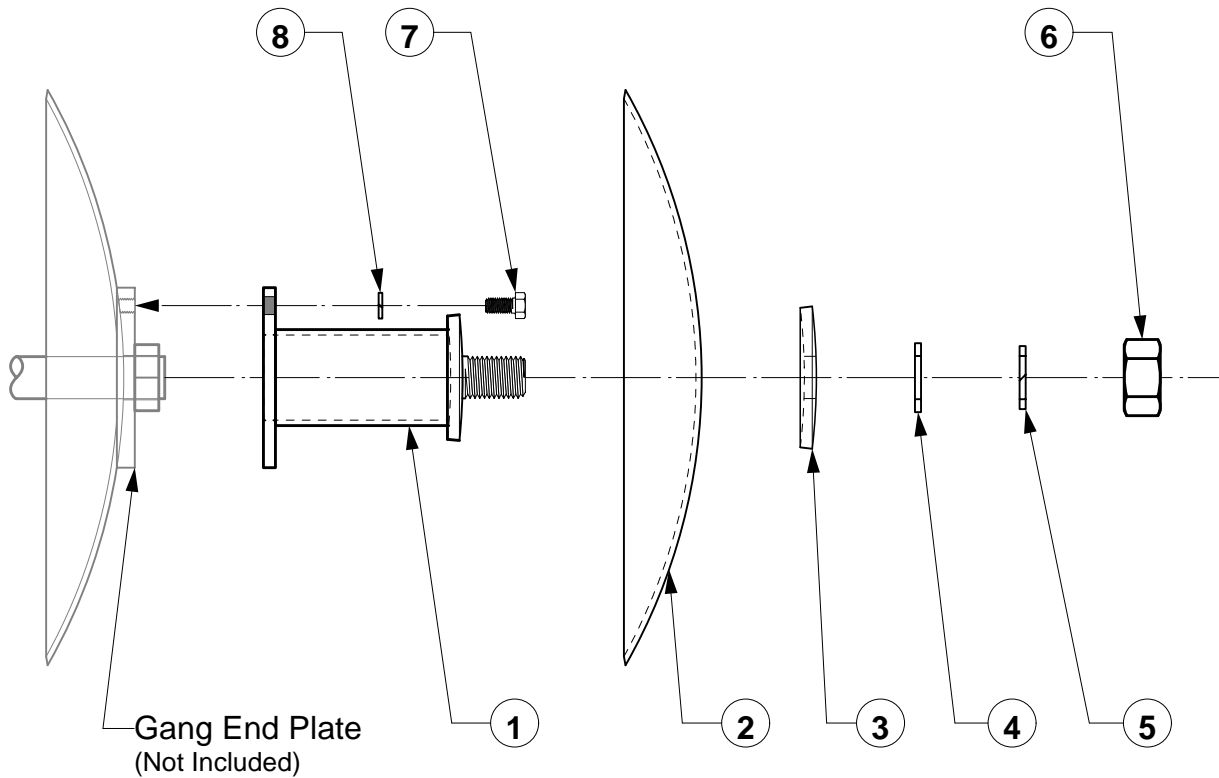

<u>Ref No.</u>	<u>Old Part No.</u>	<u>New Part No.</u>	<u>Description</u>	<u>Qty. / Set</u>
1.	SD-175ia	GDP-OBE000	Outside Blade Extension	2
2.	-----	-----	Disc Blade	2
3.	SD-175C-01	GDP-28FS01	6" Dia. End Plate	2
4.	FFW175	FWASHER-28	1-3/4" Flat Washer	2
5.	FLW175	LWASHER-28	1-3/4" Lock Washer	2
6.	FJN175	HXNUTJ28NC	1-3/4" Jam Nut	2
7.	FHB063X0125	CSNC510020	5/8" X 1-1/4" Gr. 5 Hex Bolt	6
8.	FLW063	LWASHER-10	5/8" Lock Washer	6

# T.G. SCHMEISER CO., INC.®

## Limited Warranty Statement

T. G. Schmeiser Co., Inc. warrants each new Schmeiser® product to be free from defects in material and workmanship. This warranty is applicable only for the normal service life expectancy of the product or components, not to exceed twelve (12) consecutive months from the date of delivery of the new Schmeiser product to the original purchaser.

Genuine T. G. Schmeiser Co., Inc. replacement parts and components will be warranted for 365 days from date of purchase, or the remainder of the original equipment warranty period, whichever is longer.

Under no circumstances will it cover any merchandise or components thereof, which, in the opinion of the company, has been subjected to misuse, unauthorized modifications, alteration, an accident or if repairs have been made with parts other than those obtainable through T. G. Schmeiser Co., Inc.

The Company in no way warrants engines, batteries, cylinders, tires or other trade accessories since these items are warranted separately by their respective manufacturer. Expendable components such as points, shanks, blades, rings, bearings, teeth, and the like are excluded from this warranty.

Our obligation under this warranty shall be limited to repairing or replacing, free of charge to the original purchaser, any part that, in our judgment, shall show evidence of such defect, provided further that such part shall be returned within thirty (30) days from date of failure to T. G. Schmeiser Co., Inc., routed through the dealer and distributor from whom the purchase was made, transportation charges prepaid.

This warranty shall not be interpreted to render T. G. Schmeiser Co., Inc. liable for injury or damages of any kind or nature to person or property. This warranty does not extend to the loss of crops, loss because of delay in harvesting, or any expense or loss incurred for labor, substitute machinery, rental or for any other reason.

**Except as set forth above, T. G. Schmeiser Co., Inc. shall have no obligation or liability of any kind on account of any of its equipment and shall not be liable for special or consequential damages. T. G. Schmeiser Co., Inc. makes no other warranty, expressed or implied, and, specifically, T. G. Schmeiser Co., Inc. disclaims any implied warranty or merchantability or fitness for a particular purpose. Some states or provinces do not permit limitations or exclusions of implied warranties or incidental or consequential damages, so the limitations or exclusion in this warranty may not apply.**

This warranty is subject to any existing conditions of supply, which may directly affect our ability to obtain materials or manufacture replacement parts.

T. G. Schmeiser Co., Inc. reserves the right to make improvements in design or changes in specifications at any time, without incurring any obligation to owners of units previously sold.

No one is authorized to alter, modify or enlarge this warranty nor the exclusion, limitations and reservations.

**WARRANTY VOID IF NOT REGISTERED  
WITHIN 30 DAYS OF PURCHASE DATE**